



# 제품 안내

Product Catalog

Tel. 052-920-1545 Fax. 052-254-1201



## 8단 자동 변속기 전륜

Automatic Transmission Part FF Type 8-speed

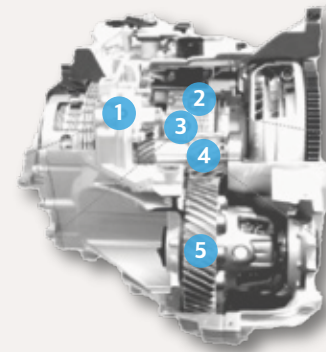

GEAR-SUN, MID



GEAR-ASSY ANN, MID



GEAR-ASSY ANN, FRT



FORGING PART



PINION GEAR



SHAFT O/P



GEAR-DIFF DRIVE



FORGING PART



FORGING PART

## 8단 자동 변속기 후륜

Automatic Transmission Part FF Type 8-speed

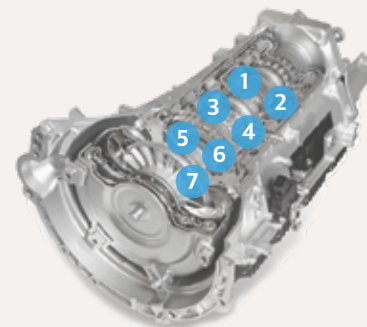

RR SUN DOUBLE GEAR



RR ANN GEAR



RR SUN SINGLE GEAR



MID ANN GEAR

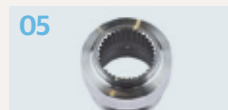

MID SUN GEAR



FRT SUN GEAR



FRT ANN GEAR



PINION GEAR

## 6단 자동 변속기 전륜

Automatic Transmission Part FF Type 6-speed

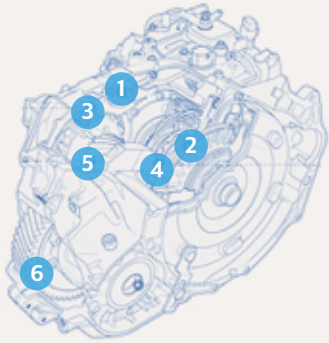

01



**CARRIER**

PLATE-PL, FRT/CUP-PL,RR  
Annual Volume : 840,000 set

02



**GEAR PINION**

FRT/MID/RR  
Annual Volume : 35,000,000 pcs

03



**PISTON**

U/D, O/D, 35R  
Annual Volume : 3,000,000 set

04



**GEAR-ASSY ANN, FRT**

FRT/MID/RR  
Annual Volume : 330,000 set

05



**GEAR TRANSFER**

GEAR DRIVE/DRIVEN  
Annual Volume : 500,000 set

06



**FINAL GEAR**

SHAFT OUTPUT/DIFFERENTIAL DRIVE GEAR  
Annual Volume : 330,000 set

## 7단 자동 변속기

Dual-clutch Transmission Part FF Type 7-speed

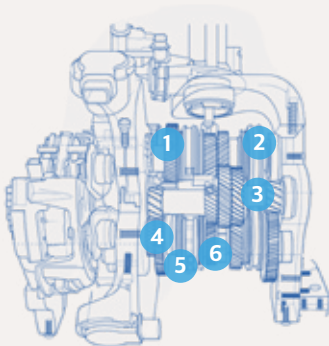

01



**SHAFT**

SHAFT-OUTPUT 1st  
Annual Volume : 700,000 set

02



**GEAR TRANSFER**

GEAR DRIVE/DRIVEN  
Annual Volume : 100,000 set

03



**SHAFT**

SHAFT-INPUT 2nd  
Annual Volume : 700,000 set

04



**GEAR SPEED**

GEAR-INPUT/OUTPUT  
Annual Volume : 700,000 set

05



**CLUTCH**

GEAR-CLUTCH 1st  
Annual Volume : 700,000 set

06



**SHAFT**

SHAFT-OUTPUT 2nd  
Annual Volume : 700,000 set

## 무단 변속기

Continuously Variable Transmission Part

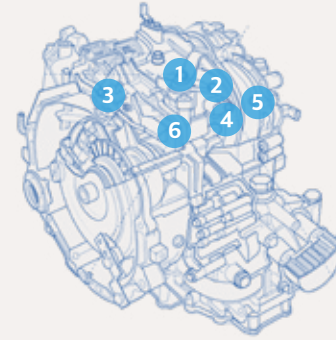

01



**PULLEY**

SHEAVE-SECONDARY FIXED  
Annual Volume : 100,000 set

02



**PULLEY**

SHEAVE-PRIMARY FIXED  
Annual Volume : 100,000 pcs

03



**PISTON**

PISTON SECONDARY  
Annual Volume : 100,000 set

04



**CARRIER**

SHAFT-PLANET CARRIER, FRT  
Annual Volume : 100,000 set

05



**SHAFT**

SHAFT-OUTPUT  
Annual Volume : 100,000 set

06



**PULLEY**

SHEAVE-PRIMARY MOVABLE  
Annual Volume : 100,000 set

## 수동 변속기

Manual Transmission Part

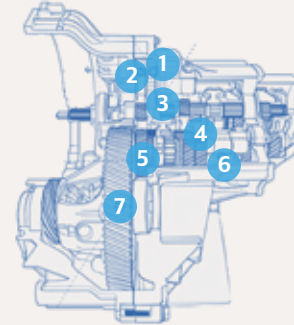

01



**SHAFT-REVERSE**

SHAFT-REVERSE IDLER  
Annual Volume : 300,000 pcs

02



**GEAR-REVERSE**

GEAR-RVS IDLER  
Annual Volume : 300,000 pcs

03



**CLUTCH**

GEAR-CLUTCH 1~6th  
Annual Volume : 1,200,000 pcs

04



**SHAFT**

SHAFT-OUTPUT 1st/2st  
Annual Volume : 50,000 pcs

05



**GEAR-SPEED**

GEAR-SPEED OUTPUT  
Annual Volume : 300,000 pcs

06



**GEAR-SPEED**

GEAR-INPUT/OUTPUT  
Annual Volume : 1,500,000 pcs

07



**GEAR-DIFFERENTIAL**

GEAR-DIFFERENTIAL DRIVE  
Annual Volume : 300,000 pcs