

A thick, vertical orange bar on the left side of the slide.

BEST **MOBILITY** **PARTNER**

One Dream To One World

OTO INDUSTRY · NEO OTO

Table Of Contents

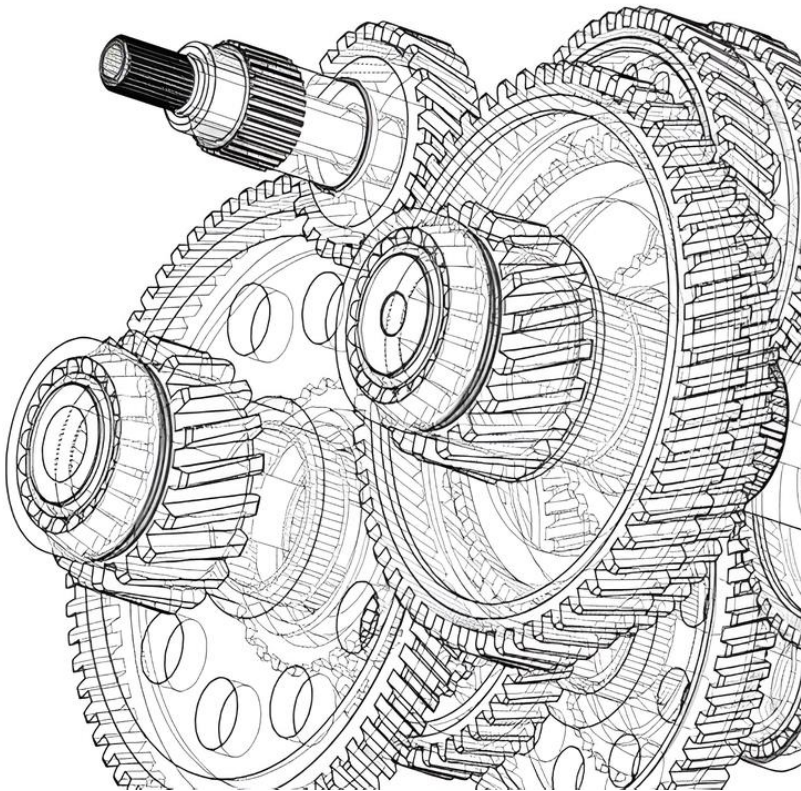

- 01 ● Company
- 02 ● Product
- 03 ● Facility
- 04 ● R&D Status
- 05 ● Certificate
- 06 ● ESG

History

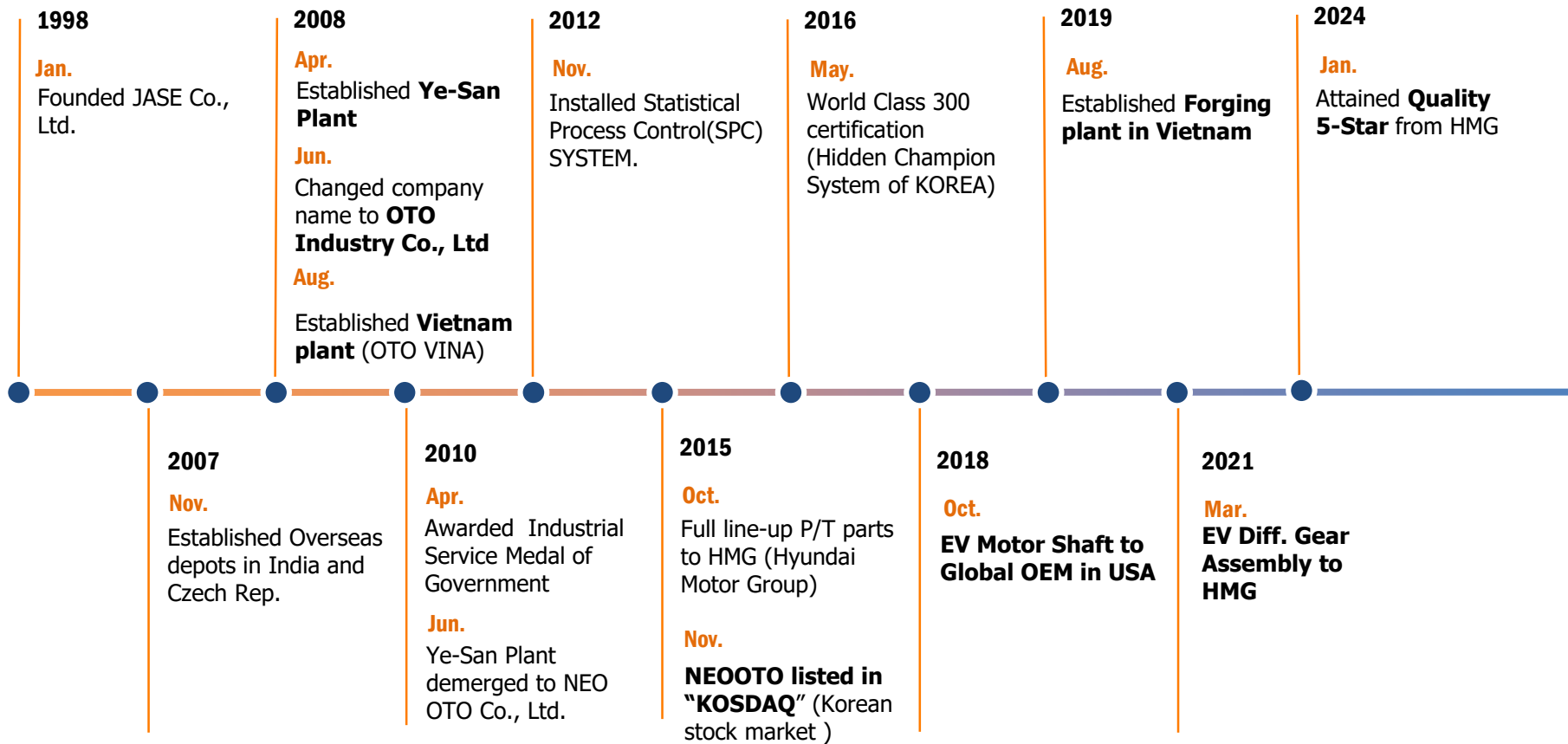

OTO Group Organization

4

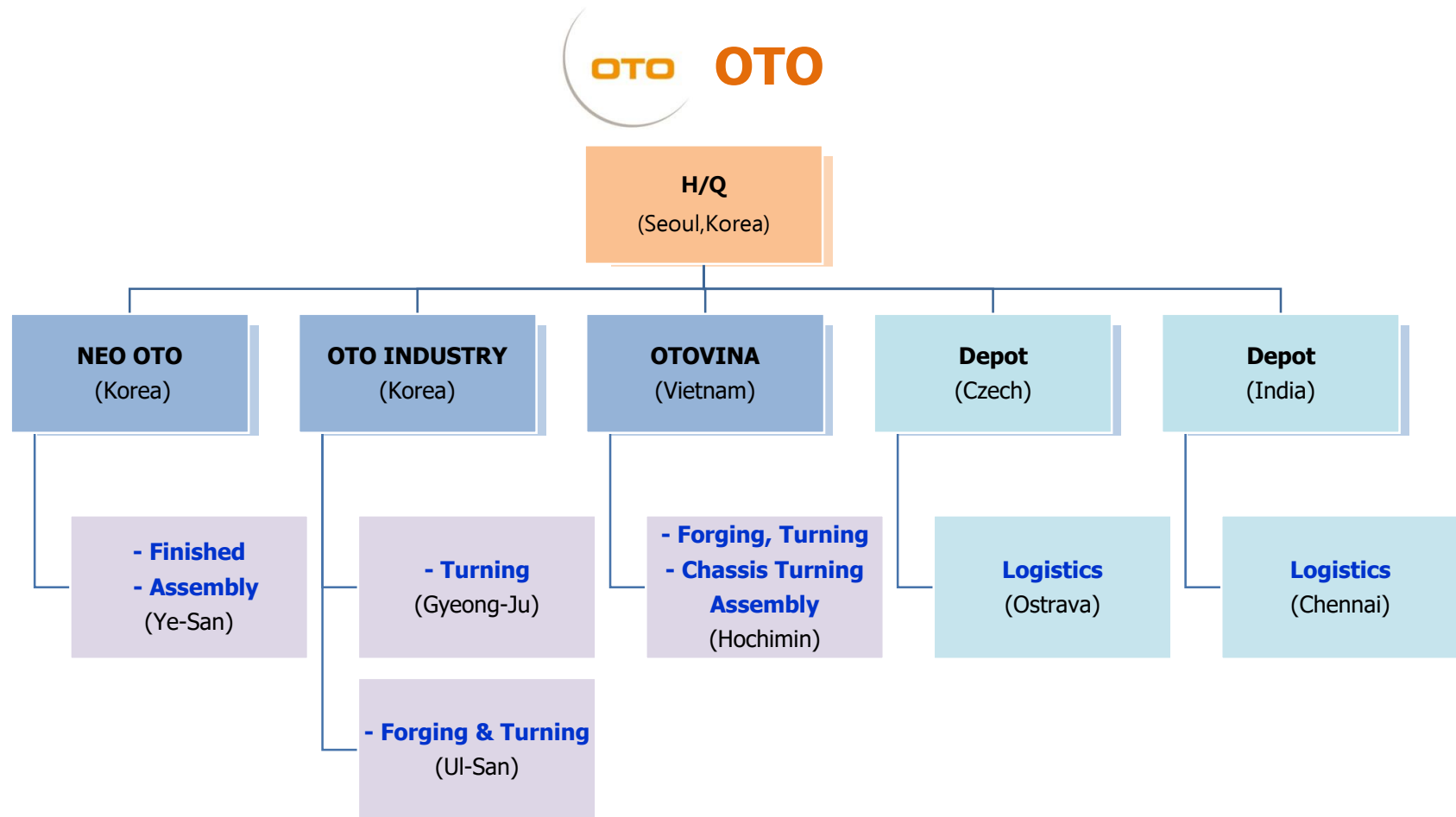

Locations

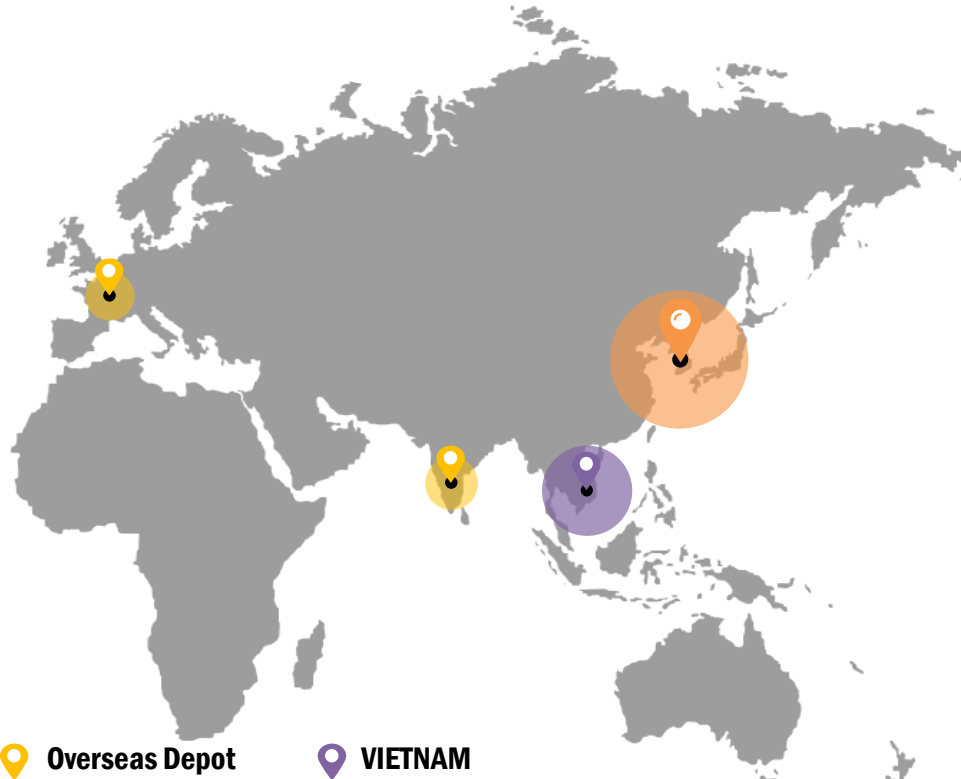

Overseas Depot
 - India
 (CHENNAI _ Logistics)
 - Czech
 (OSTRAVA _ Logistics)



OTO VINA Forging & Machining
Production capacity: 1.4Mil. units/year
 - Gear Speed ,Gear Clutch, Gear Diff
 - Output Shaft, Pulley
 - Chassis (Axle ass’y, Break Disc, Knuckle)
 - Distance : 32km (from Ho Chi Minh Airport)

SOUTH KOREA



OTO Headquarter in Seoul

NEO OTO YESAN 1st ~ 3rd Plants



Production capacity: 39Mil. units/year
 - Gear-Pinion, Diff Drive Gear & Output Shaft
 - Annulus Gear ,Differential Carrier Assembly
 - T/F Drive/N Gear, Reducer
 - Distance : 156km (from Incheon Airport)



OTO INDUSTRY GYEONGJU Plant

Production capacity: 20Mil. units/year
 - Output Shaft, Speed Gear, Annulus Gear
 - T/F Drive/N GEAR, Clutch Gear, CVT Parts
 - Distance : 365km (from Incheon Airport)



OTO INDUSTRY ULSAN Plant

Production capacity: 5.2Mil. units/year
 - Input & Output Shaft
 - T/F Drive GEAR
 - Distance : 381km (from Incheon Airport)

Client Distribution

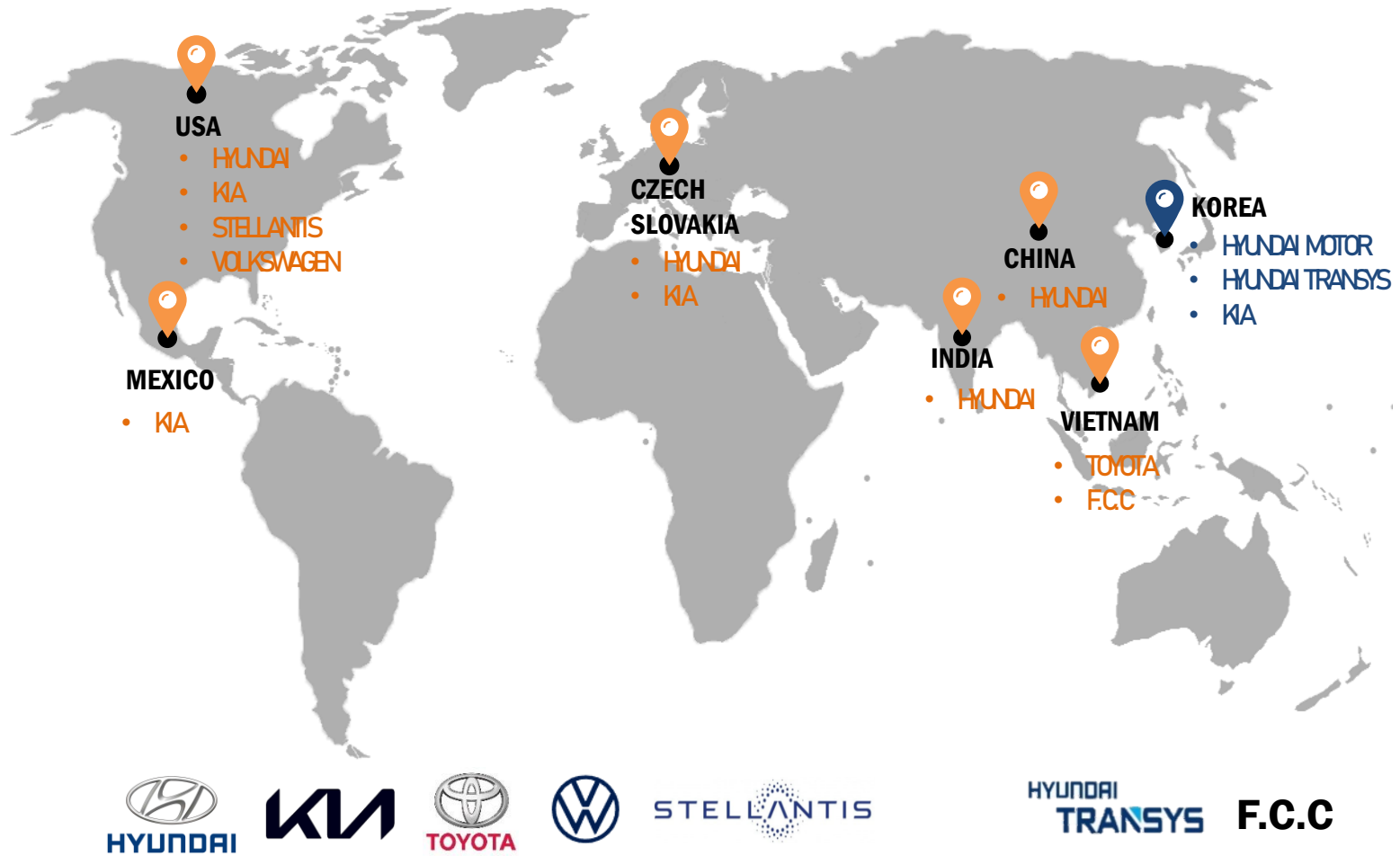

Sales Forecasting

Annual Turnover

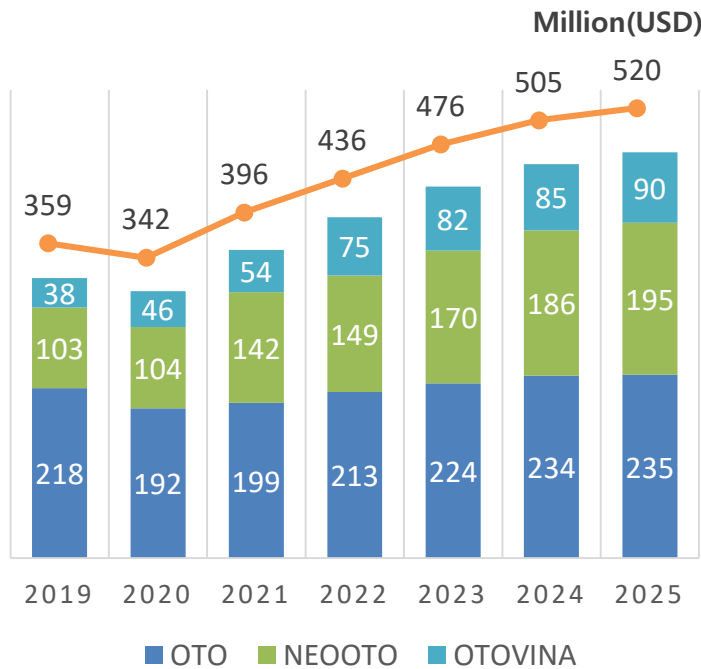

◆ **2024-2025:** Ready-made Order

◆ **Sales Portion:** Domestic 70%, Export 30%
 ※Export is made through indirect route

Sales Portion (2023)

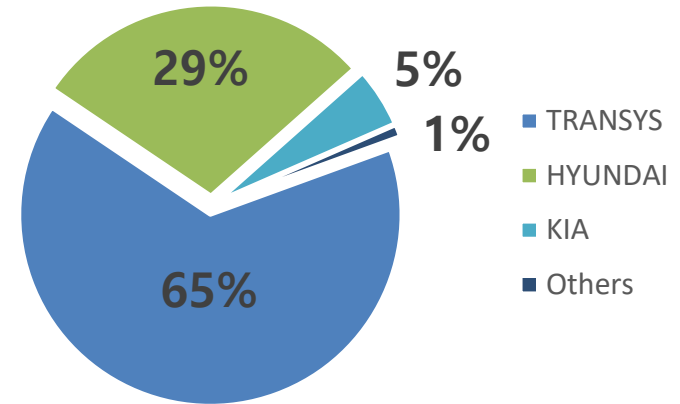

◆ Focused on HMG demands : 99% in 2021

◆ Expanding to Global OEMs : **1%** in **2021**
5% in **2023**~ fixed

Transmission, EV Reducer & Motor Parts

Transmission Parts

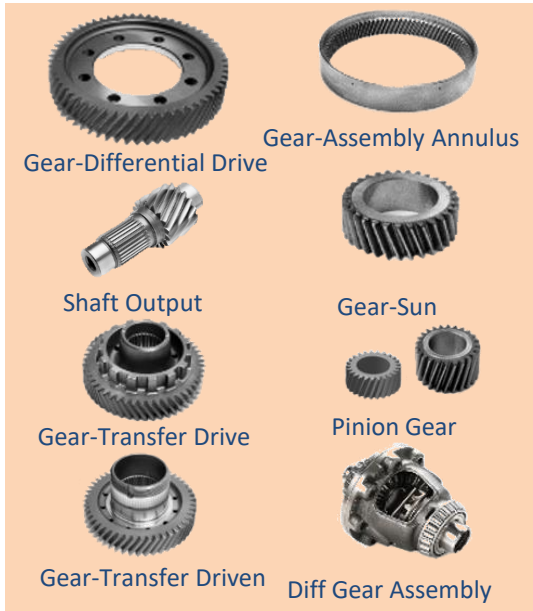
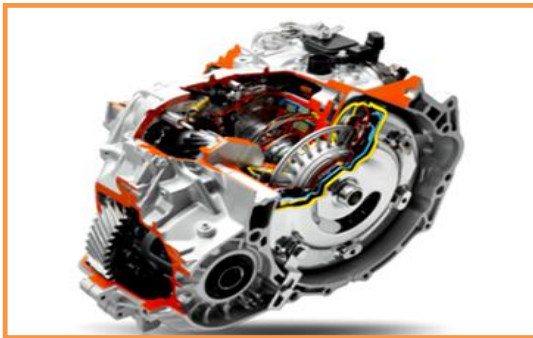

EV Motor Parts



EV Reducer



EV REDUCER Parts

EV B,C SEGMENTS

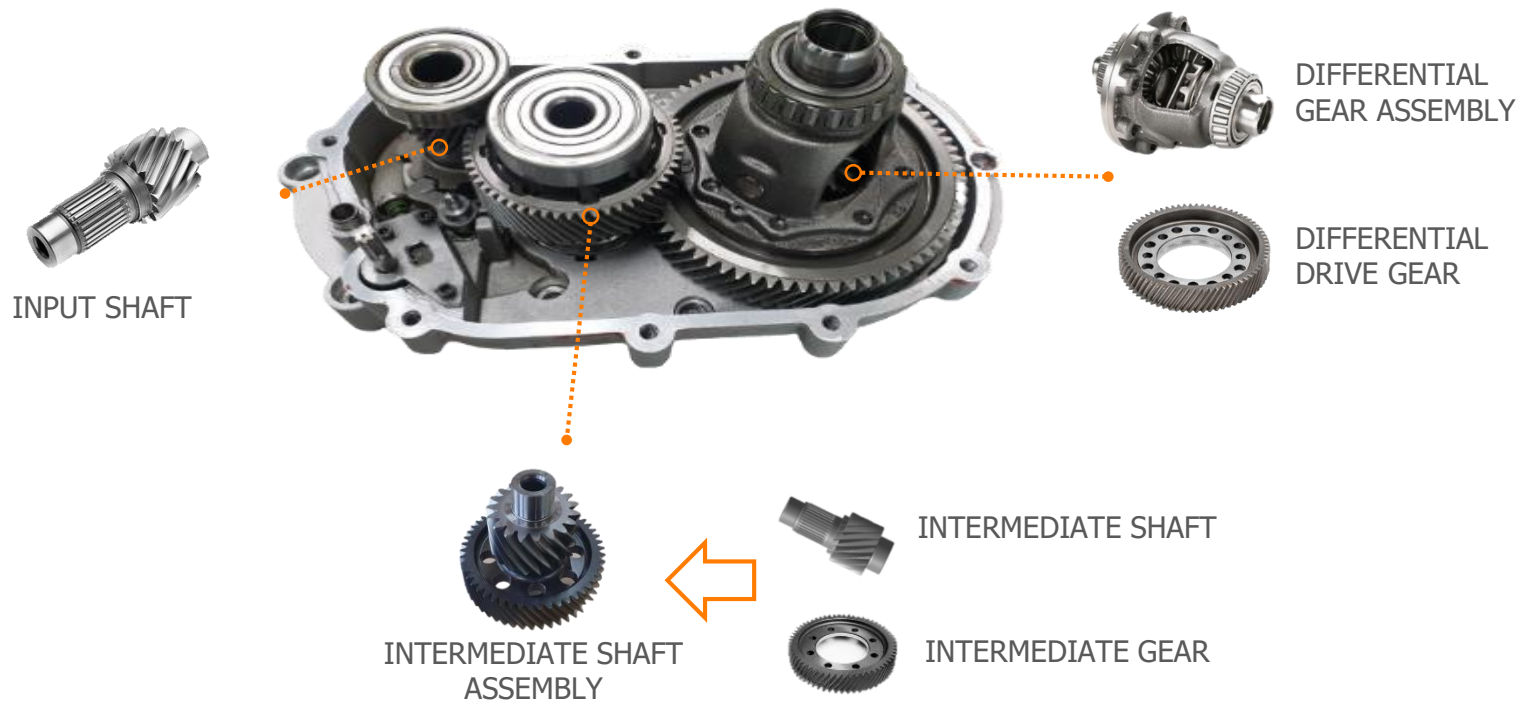

A/T Parts_8speed

FF Type 8 Speed Automatic Transmission Part

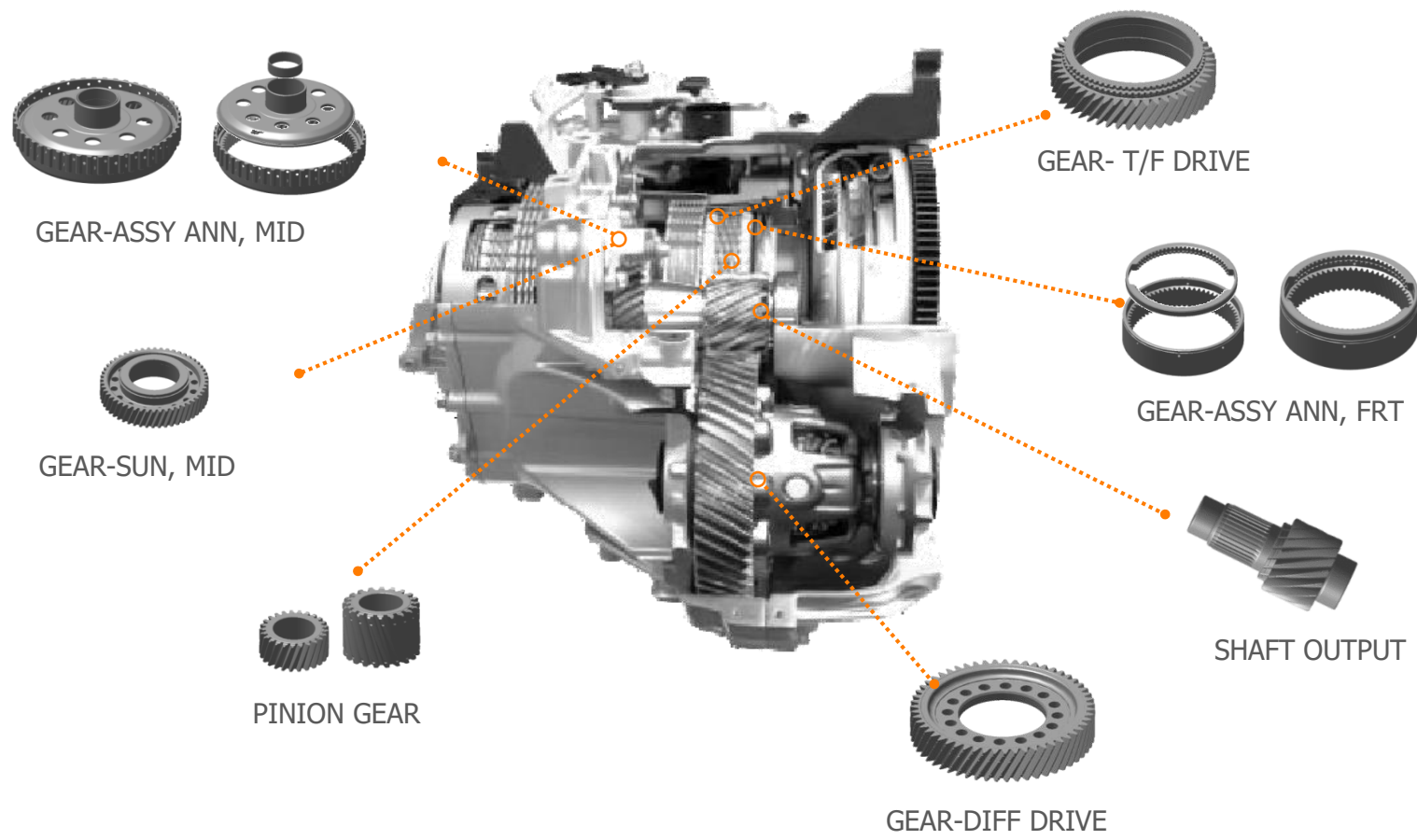

A/T Parts_6speed

FF Type 6 Speed Automatic Transmission Part

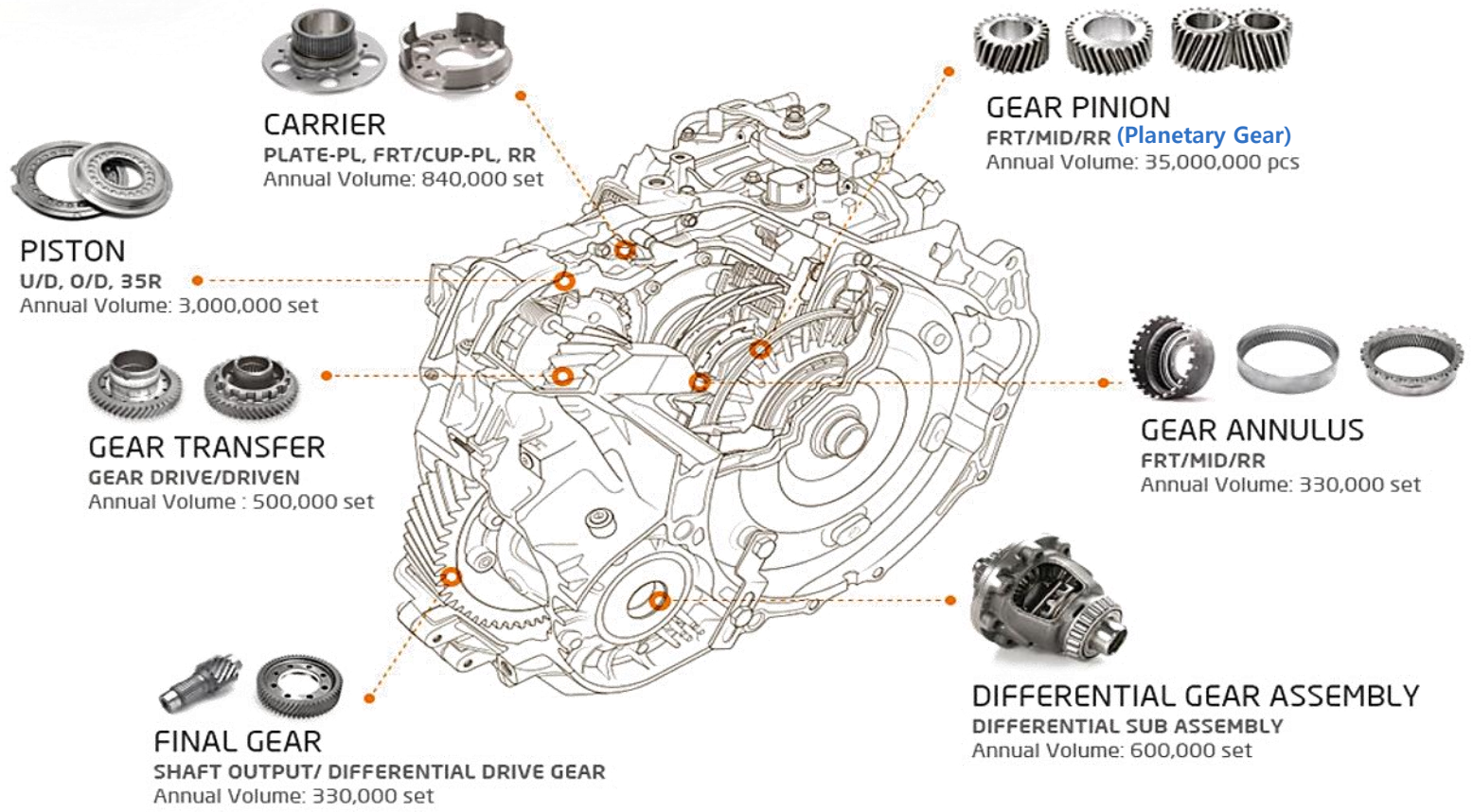

DCT Parts

FF Type 7 Speed Dual Clutch Transmission Parts

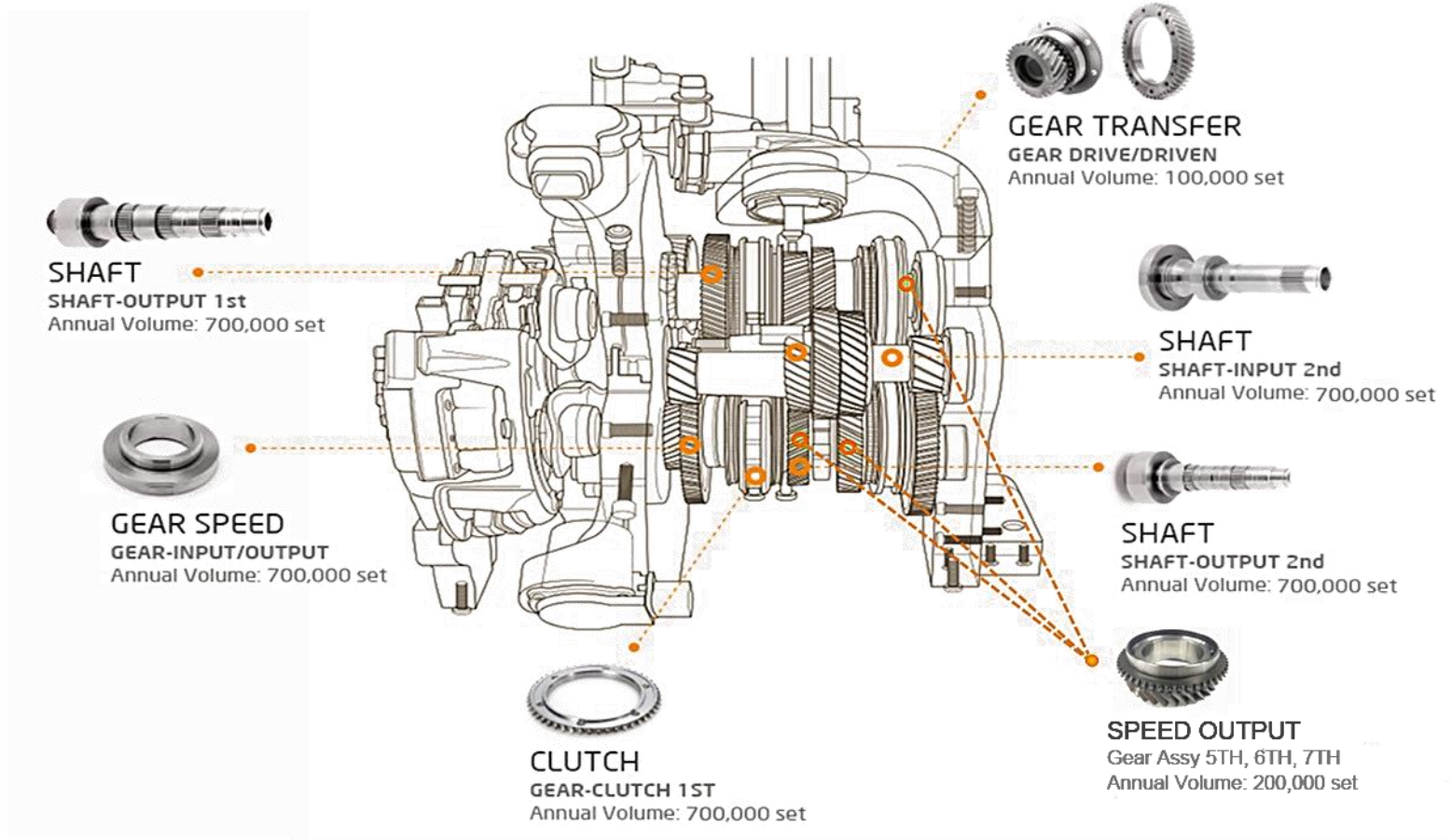

CVT Parts

Continuously Variable Transmission Parts

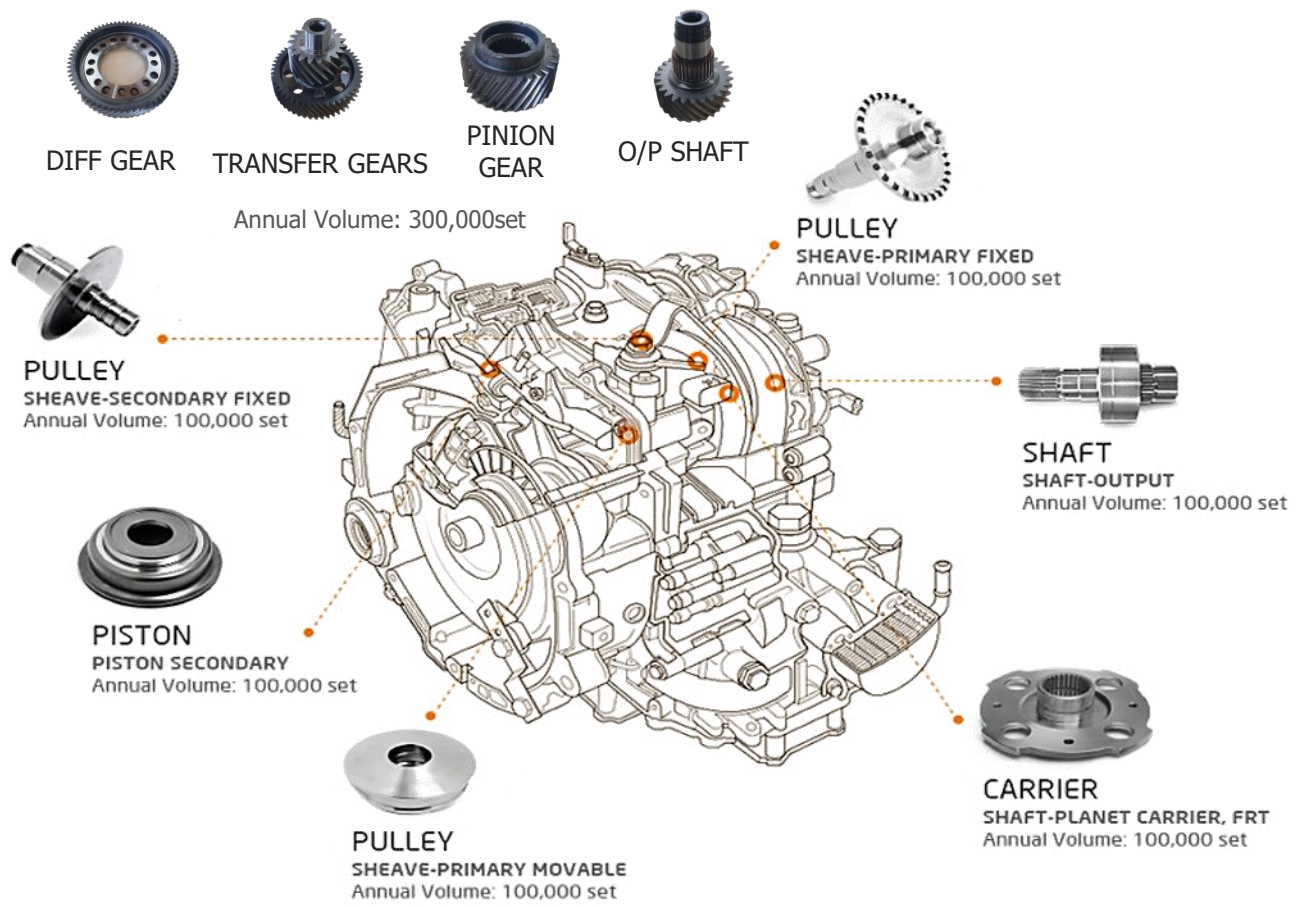

Chassis Parts (Vietnam)

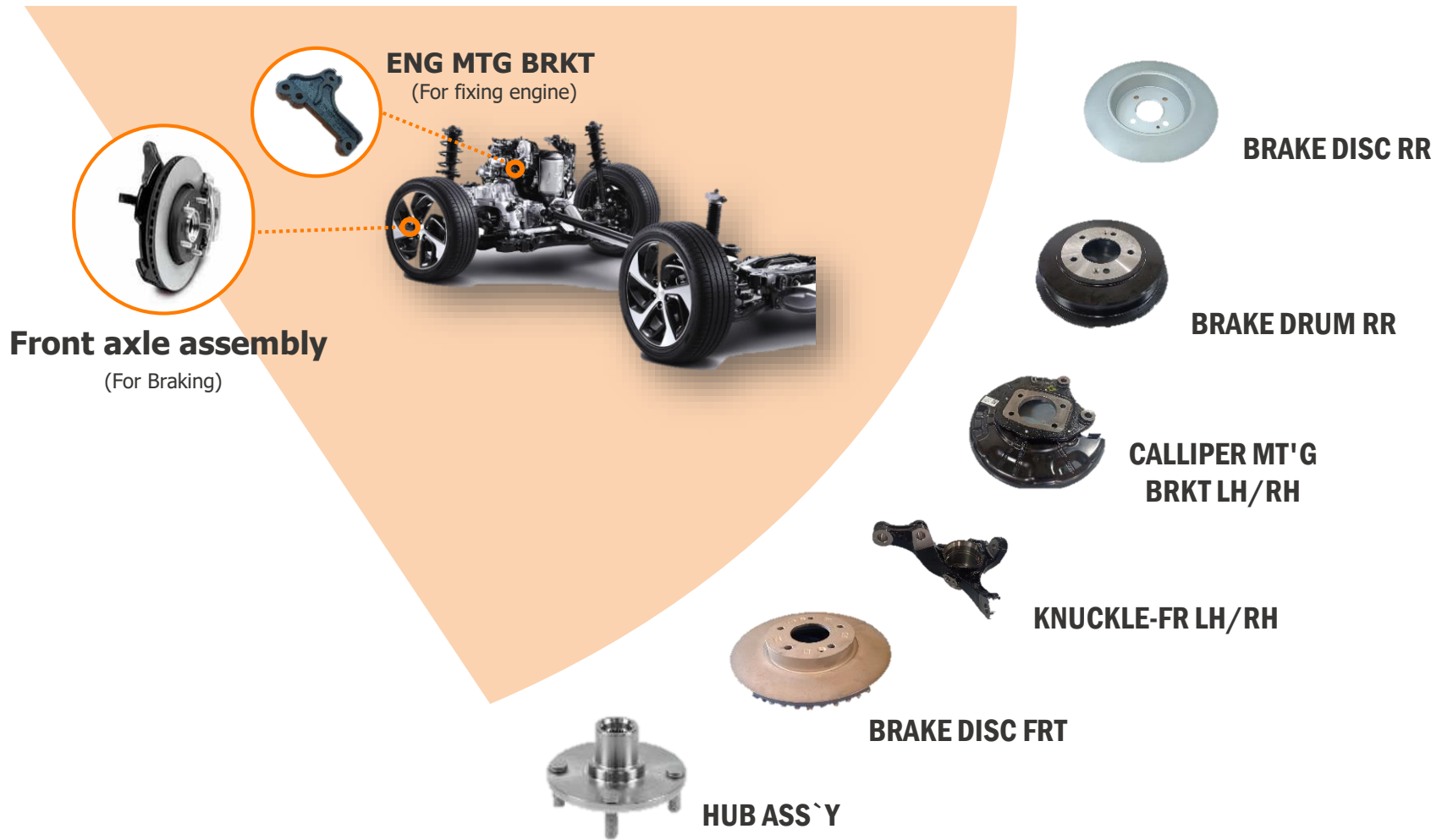

Gear Line

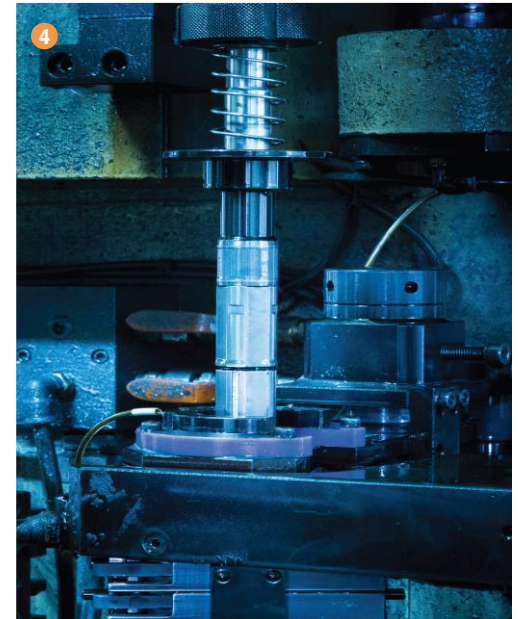
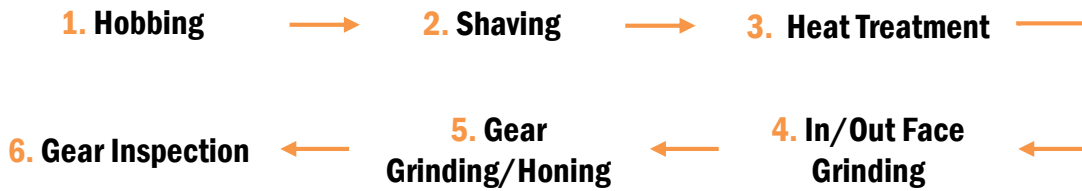
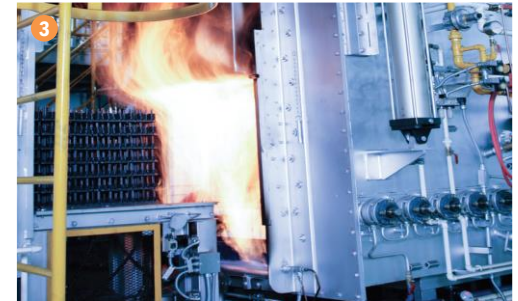
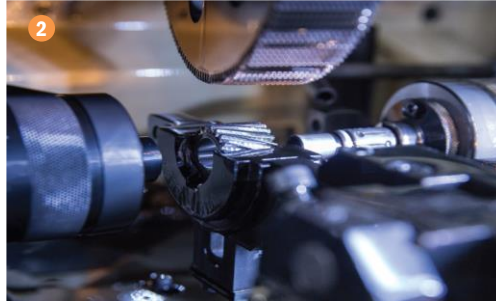

EV Motor Shaft Line

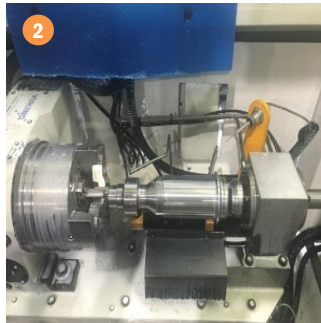

1. Hot Forging

2. Soft Turning

3. Broach

4. Shaper

5. Hobbing

6. Heat Treatment (Vacuum)

6

12. Auto Inspection

11. Washing

10. Gear Honing

9. Grinding

8. Hard Turning

7. Hard Shot Peening

7

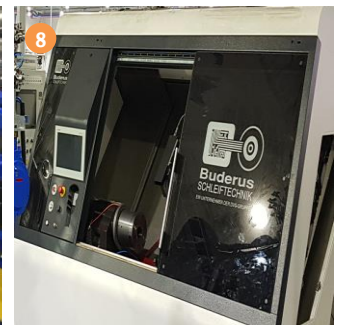

Differential Gear Assembly Line

17

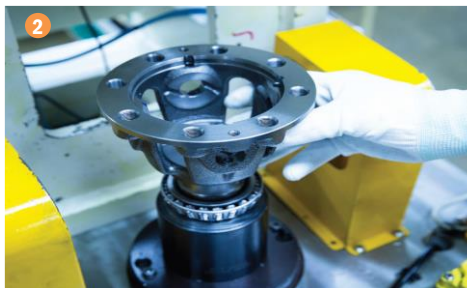

1. Incoming Inspection



2. Sub Assembly



3. Main Assembly



6. Lot Marking



5. Backlash & Air Leak Test



4. Automatic Inspection



Inspection Equipment & Tooling management



Quality Management



Process Inspection

Measuring Item

- OBD
- RUN-OUT
- IN.DIA.
- E.F.WIDTH



Final Inspection

Measuring Item

- OBD
- NICK
- RUN-OUT
- IN.DIA.
- E.F.WIDTH
- E.FACE



Dimension Checking

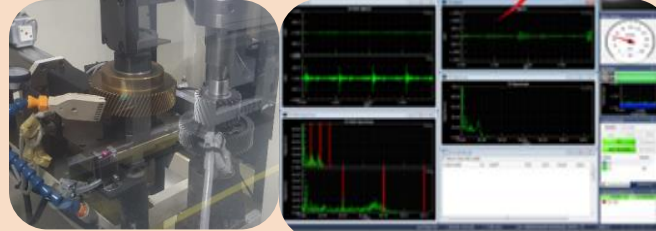

Gear checking with frequency for NVH

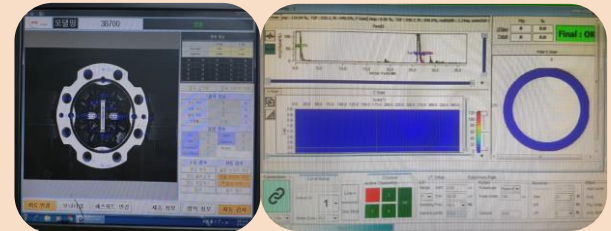

Welding Bid checking with scanner & ultrasonic

EV Reducer (Gear box)

Reducer



ADVANTAGES





- ✓ **Self-designed and developed EV Reducers with wide range from 12.6kW to 150kW**
- ✓ **Customizing design of Reducer**
- ✓ **Integrated Parking system without additional parking gear**

2 Speed Reducer



EV Reducer/ Transmission Line-Up





21

	12.6kW	20kW	85kW	100kW 2 Speed [FR-Type]	150kW 2 Speed (FF-Type)
Products					
Max. Power	15 kW	30 kW	100 kW	100 kW	150 kW
Gear Ratio	9.34 : 1	8.2 : 1	7.35 : 1	2.9:1 (1st), 1.8:1 (2nd)	10.2:1 (1st), 6.2:1 (2nd)
Axial Distance	180 mm	150 mm	193 mm	102 mm	189 mm
Max Torque	65 Nm	150 Nm	288 Nm	350 Nm	400 Nm
Dry Weight	12 Kg	15 Kg	21.5 Kg	31.5 Kg	35.8 Kg / 35.4 Kg
Size [mm]	385 x 230 x 230	370 x 270 x 200	440 x 280 x 210	307.2 mm	310.9 mm / 302.8 mm
Application	Twizy, Danigo I	Cebo, Masta	IONIQ EV, Volt EV	Porter EV, Bongo EV	IONIQ EV, Volt EV
Segment	Compact	Compact	B, C	C, D, Commercial Vehicle (1Ton)	C, D Commercial Vehicle (1Ton)
Process	Design ⇒ Test	Design ⇒ Test	Design ⇒ Test	Test ⇒ Vehicle Test	Prototype Production ⇒ Test

Test & Proto Equipment

T/M DYNAMOMETER



	Name (Q'TY)	Maker (Country)	Main Spec.
	Input Motor (1Set)	AKH (Germany)	<ul style="list-style-type: none"> Rated Power : 160kW Max. Torque : 400Nm Max. Speed : 16,000rpm Air Cooling Type
	Out Motor (2Set)	SIEMENS (Germany)	<ul style="list-style-type: none"> Rated Power : 275kW Max. Torque : 10,943Nm Max. Speed : 2,800rpm Air Cooling Type
	Noise Chamber (1Set)	VMV-Tech (Korea)	<ul style="list-style-type: none"> Sliding Shut Type Blocked Outside Noise
	Mobile H/W Data Acquisition (1Set)	LMS SIEMENS (Germany)	<ul style="list-style-type: none"> Channel : 16ch M'ment Time Data of NVH Analysis of Overall Level Analysis of Sound Quality

SHIFT PERFORMANCE TESTER



PROTO ASSEMBLY EQUIPMENTS



Oil-Pressure Press







Heating Chamber

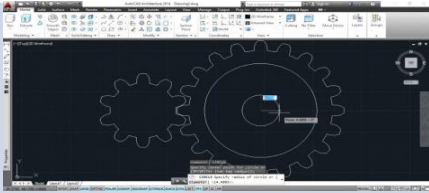
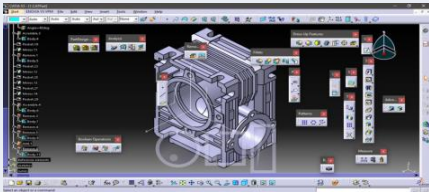

Air-Leak Tester

Software Information

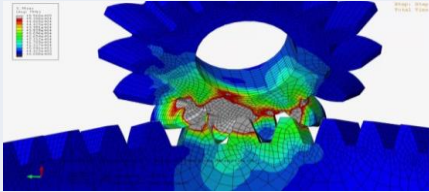
23

Div.	Name (Maker)	Image	Q'TY	Contents
2D & 3D Design	AutoCAD (AUTODESK)		14	<ul style="list-style-type: none"> 2D Parts & Assembly design Detailed drawing design
	CATIA V5 (Dassault Systems)		3	<ul style="list-style-type: none"> 3D Parts & Assembly design BOM optimization SIMULATION with design data
Design & Calculation	KISSsoft & KISSys (KISSsoft)		1	<ul style="list-style-type: none"> Gearbox design and Strength calculation Gear driving calculation of gear set Efficiency and power loss calculation for Bevel/ Spur/ Helical gear
Systems & Parts Analysis	ABAQUS (Dassault Systems)		1	<ul style="list-style-type: none"> 3D Nonlinear Durability Analysis Multiphysics integration analysis for structural, thermal, electrical, etc. Finite element analysis (collision, structural durability, noise, vibration, etc.)
TCU Logging & Analysis	CANoe (VECTOR)		1	<ul style="list-style-type: none"> CAN/LIN Network Connection Analysis Inject CAN signals into single controller(TCU) Controller(TCU) CAN Simulation CAN Network Test

ESG

ESG Strategy

OTO has ESG vision to fulfill 3 aim and 6 key tasks for each area of environment, society, and governance.

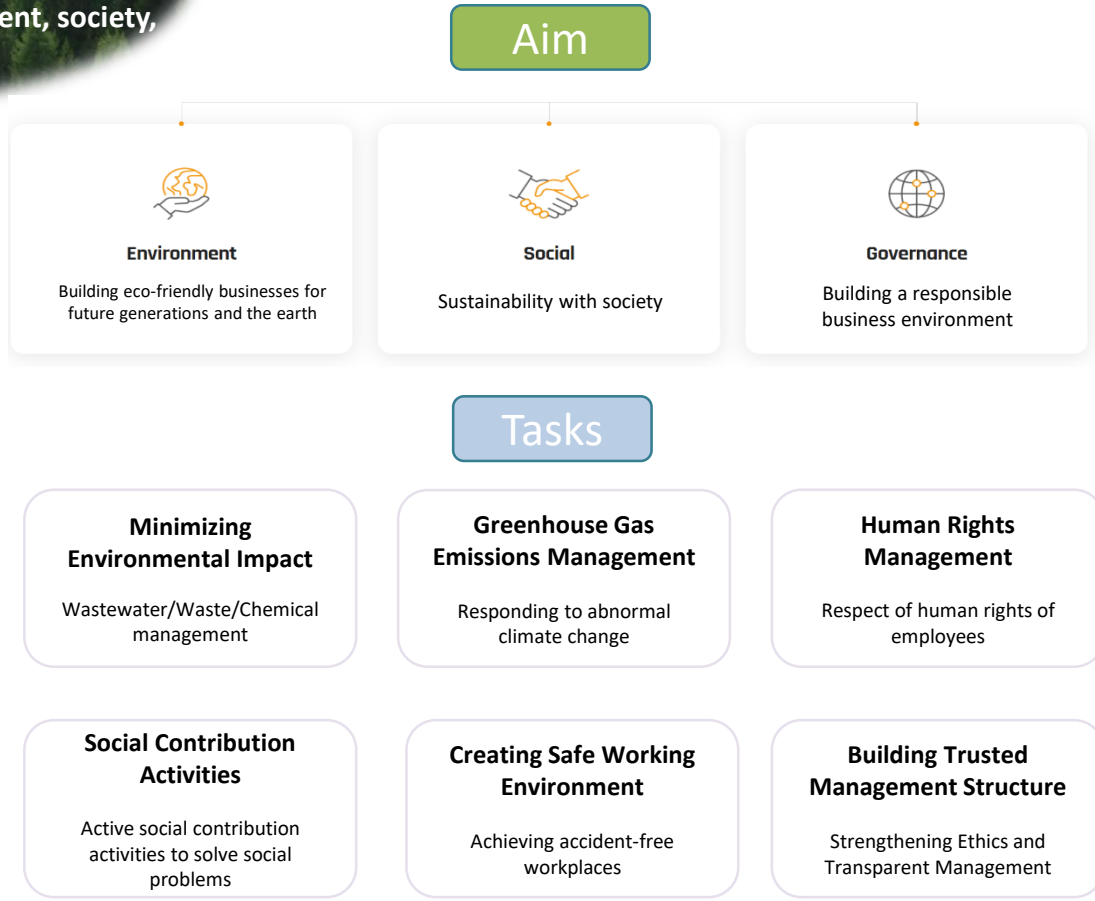

ESG

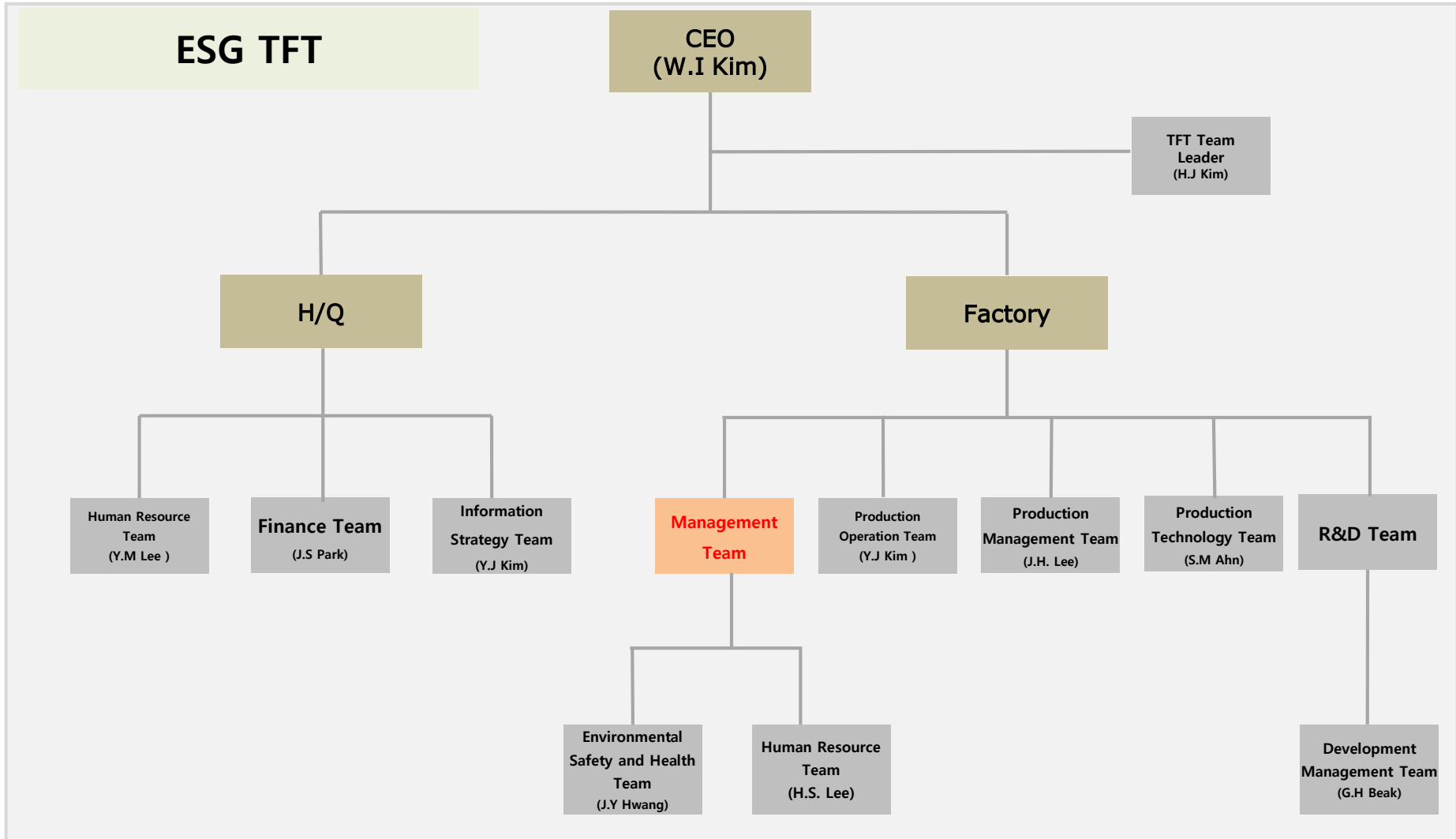

ESG



Water Resources Management

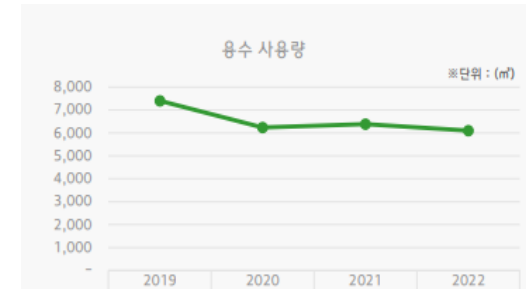

- The installation of water-saving devices indirectly contributes to the prevention of desertification

Solar Panel



Safety & Health Management

- To achieve workplace accident-free through safety and health policies and regulations establishment and compliance

- Installation of Solar Panel contributes to use of reusable resource

ESG

Social Contribution Activity

OTO continues to carry out social contribution activities with the belief that good companies can make good products



Volunteer Service



Community Donation





One Dream To One World

Head Office

602 Royal bldg., 19, Saemunan-ro 5-gil,
Jongno-gu, Seoul, Korea
Tel. 82-2-732-2871~2
Fax. 82-2-6732-2870
E-mail. hckim@oto.kr
Web. www.oto.kr

NEO OTO Co., LTD

8, Durumeori, Sappgyo-eup, Chungnam,
Korea
Tel. 82-41-337-1730
Fax. 82-41-337-1736
Web. www.neoto.kr

OTO Industry Co., LTD

60, Sinpyeonggongdan-gil,
Geoncheon-eup, Gyeongju-si,
Gyeongsangbuk-do, Korea
Tel. 82-54-750-6000
Fax. 82-54-751-9320

OTOVINA Co., LTD

Nhon Trach 5 Industrial Zone,
Dongnai Province, Vietnam
Tel. 84-613-569-391
Fax. 84-316-569-393

Logistics Depot in India

Plot No.52, Royal Garden,
Goparasanallur Village,
Kattupakkam, Chennai 600 056
Tel. 91-70-7833-6698
C.P. 91-9790906159

Logistics Depot in Czech

OTO CZECH, s.r.o.
Národních mučedníků 499, Frýdek, 738 01
Frýdek-Místek, Tschechien
Tel. 420-558-433-143
C.P. 420-724-593-007